

SR-29-N ACOUSTIC SYSTEM



KELONIK CINEMA SOUND

Acoustic system specially designed for high dynamic surround systems suitable for spectacular systems such as Dolby Atmos, Auro 11.1 or similar

With the advent of the new 3D digital projection formats, audio systems in movie theatres need to evolve so that the audience can be immersed in the sound field and enjoy a true 3D sound experience. Technologies like Atmos or Auro 11.1 use speaker systems installed in the ceiling of the auditorium to wrap the audience and locate any sound in any point in the auditorium. The K.C.S. engineering department has developed a new two-way ceiling speaker system to fulfil the needs for S.P.L., coverage, frequency, response and sound quality with the new formats.



The SR-29-N speaker system is designed to operate as a surround channel enabling proper coverage of the whole auditorium. To this end, it features a 12" low-frequency speaker with high sensitivity and large power handling characteristics, providing a high level of bass sound and extended frequency response.

- Two-way speaker system with maximum S.P.L. and minimum distortion.
- Optimised for 3D surround sound reproduction.
- Constant radiation horns.
- Special brackets and accessories for ceiling installation.
- 12" speaker and 3" coil for extended and for spectacular bass response and a 2" medium/high frequency unit.

SR-29-N ACOUSTIC SYSTEM

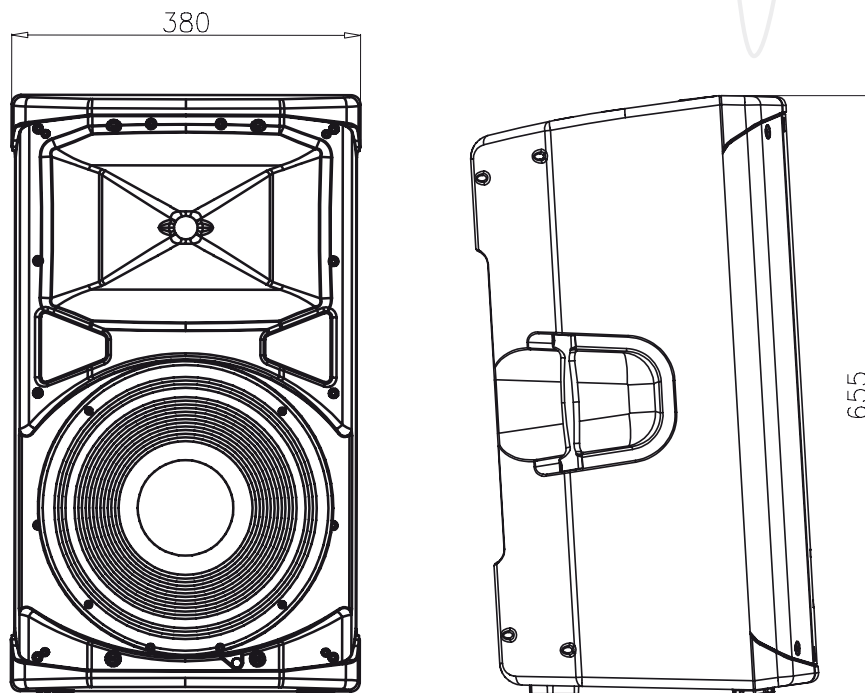

TECHNICAL DATA

RMS (Average) power handling(1)	400 W
Peak power handling	1600 W
Frequency range (-10 dB)	50 Hz – 20 kHz
Nominal Impedance	8 Ohms
Sensitivity 1W/1m	102 dB S.P.L. Half-space 99 dB S.P.L. Free-field
Rated maximum peak S.P.L.	133 dB S.P.L. 1 m
Beamwidth	90°H x 50° V
Dimensions (H x W x D)	65 x 38 x 34,60 cm
Weight	18.9 kg

(1) Based on a 2 hour test using a continuous 6 dB crest factor pink noise signal band limited according to IEC 268-1 (1985).