

# S-7801

Item Code

47054-A



## SCREEN CHANNEL

S-7801

---

SUMINISTROS KELONIK SA  
C/ Badajoz, 159 bis - 08018 Barcelona - Spain  
Tel. +34 93 300 43 61  
Updated (DD/MM/YYYY): 21/05/2026



## Key Features

- Optimized for Large Auditoriums: Ideal for screen channels in large venues with limited space behind the projection screen (47 cm depth).
- Bi-Amplification Ready: Designed for bi-amplification with an external active crossover at 400 Hz and a passive crossover at 1.7 kHz for the mid-high range.
- Enhanced Voice Spectrum: Features two 6.5" cone speakers and 90° x 30° constant dispersion horns to improve dialogue intelligibility.
- THX Approved: Meets rigorous THX standards, ensuring high-quality, professional cinema sound performance.

## Description

The K.C.S. S-7801 three-way speaker system is specifically designed for screen channels in large auditoriums.

With a depth of 47 cm, it is ideal for installations where space behind the projection screen is limited.

The bi-amplified system operates with an external active crossover set at 400 Hz, while a passive crossover cuts at 1.7 kHz between the mid and high ranges.

The bass section features a direct radiation cabinet with two 15" speakers, delivering powerful low-end sound.

The voice spectrum is reproduced by two 6.5" cone speakers and 90° x 30° constant dispersion horns, which enhance dialogue intelligibility compared to conventional two-way systems.

The high-frequency section includes a titanium diaphragm compression driver paired with a constant directivity horn for clear, precise high-end performance.

Additionally, the S-7801 system is THX approved, ensuring it meets the highest standards for cinema sound quality.

S-7801

# Specifications

# BI-AMPLIFIED SPEAKER

## Performances

---

Frequency Range (-10 dB)	30Hz-20kHz
--------------------------	------------

---

LF Nominal Impedance	4 Ohms
----------------------	--------

---

LF AES Power (1)	1000 W
------------------	--------

---

LF Continuous Program	2000 W
-----------------------	--------

---

MF Nominal Impedance	-
----------------------	---

---

MF AES Power (1)	-
------------------	---

---

MF Continuous Program	-
-----------------------	---

---

HF Nominal Impedance	4 Ohms
----------------------	--------

---

HF AES Power (1)	240 W
------------------	-------

---

HF Continuous Program	480 W
-----------------------	-------

---

System Sensitivity 1 W/1 m (2)	-
--------------------------------	---

---

LF Sensitivity 1 W/1 m (2)	101 dB
----------------------------	--------

---

MF Sensitivity 1 W/1 m (2)	-
----------------------------	---

---

HF Sensitivity 1 W/1 m (2)	110 dB
----------------------------	--------

---

MF / HF Bracket	Adjustable Bracket
-----------------	--------------------

---

Beam Horizontal Angle	90 degrees
-----------------------	------------

---

Beam Vertical Angle	40 degrees
---------------------	------------

---

(1) - Based on a 2 hours test using a continuous 6 dB crest factor pink noise signal band limited according to IEC 268-1 (1985).

(2) - Free field sensitivity (Half Space sensitivity +3 dB)

(3) - Rating based on test signal of filtered random noise conforming to the International Standard IEC 268-1 (pink noise with 12 dB per octave roll-off below 40 Hz and above 5000 Hz with a peak-to average ratio of 6 dB).

S-7801

---

SUMINISTROS KELONIK SA  
C/ Badajoz, 159 bis - 08018 Barcelona - Spain  
Tel. +34 93 300 43 61  
Updated (DD/MM/YYYY): 21/05/2026



# Enclosure

Dimensions cm (H x W x D) 199 x 63 x 47

Net Weight 65,95 Kg

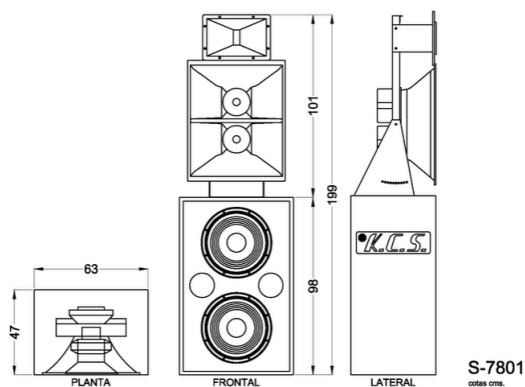

# Components

	Quantity	Reference	Item Code
Enclosure Reference	1	C-215-FV	47159-A
	-	-	-
LF Reference	2	S-15-FV	47403-A
MF Reference	2	S-6	47313-A
HF Reference	1	S-701	47204-A
MF / HF Assembly Kit	1	M/H-7801	47134-A
MF / HF Bracket	1	SP-7800	47345-A
MF Horn	1	BM-942-B	47326-A
HF Horn	1	BC-94	47239-A

S-7801

SUMINISTROS KELONIK SA  
C/ Badajoz, 159 bis - 08018 Barcelona - Spain  
Tel. +34 93 300 43 61  
Updated (DD/MM/YYYY): 21/05/2026



## Connectors

Audio Input Connectors

Push Type Terminal

---

## Spare Parts

	Reference	Item Code
LF Recone Kit	GM-S-15-FV	TBC
MF Recone Kit	-	-
HF Recone Kit	GM-S-401	47229-A
Passive Filter	-	-
MF / HF Filter	F-7801/7901-V2	47393-A

---

## EQ Settings

Check the dedicated EQ Setting page on our website  
[https://kcsspeakers.com/en/EQ\\_Setting.html](https://kcsspeakers.com/en/EQ_Setting.html)

---

S-7801