

# S-7601

Item Code

47039-A



## SCREEN CHANNEL

S-7601

SUMINISTROS KELONIK SA  
C/ Badajoz, 159 bis - 08018 Barcelona - Spain  
Tel. +34 93 300 43 61  
Updated (DD/MM/YYYY): 14/02/2025



## Key Features

- Bi-Amplification Ready: Requires an external crossover, with a 380 Hz cutoff between low and mid ranges.
- Passive Crossover: 1.8 kHz cutoff between the mid and high ranges, ensuring clear frequency separation.
- Bass Performance: Direct radiation bass cabinet with dual 15" speakers for deep, powerful low-end sound.
- Improved Voice Spectrum: 6.5" cone speaker and a 90° x 40° constant dispersion horn enhance dialogue intelligibility compared to conventional two-way systems.
- High-Frequency Driver: Compression driver with a titanium diaphragm and a constant directivity horn for precise and clear high-frequency output.

## Description

The K.C.S. S-7601 three-way speaker system is designed for screen channels in small-sized auditoriums.

With a compact 47 cm depth, it is ideal for installations with space constraints behind the projection screen.

The system is designed for bi-amplification applications and requires an external crossover with a 380 Hz cutoff between the low and mid ranges. A 1.8 kHz passive crossover is included for the mid and high ranges.

The bass section features a direct radiation cabinet with two 15" woofers for deep bass reproduction.

The voice spectrum is handled by a 6.5" cone speaker and a 90° x 40° constant dispersion horn, which enhances dialogue intelligibility compared to traditional two-way systems.

The high-frequency section is powered by a titanium diaphragm compression driver paired with a constant directivity horn, ensuring clear and accurate high-end sound.

S-7601

# Specifications

# BI-AMPLIFIED SPEAKER

## Performances

Frequency Range (-10 dB)	30Hz-20kHz
LF Nominal Impedance	4 Ohms
LF AES Power (1)	800 W
LF Continuous Program	1600 W
MF Nominal Impedance	-
MF AES Power (1)	-
MF Continuous Program	-
HF Nominal Impedance	8 Ohms
HF AES Power (1)	140 W
HF Continuous Program	280 W
System Sensitivity 1 W/1 m (2)	-
LF Sensitivity 1 W/1 m (2)	98 dB
MF Sensitivity 1 W/1 m (2)	-
HF Sensitivity 1 W/1 m (2)	104 dB
MF / HF Bracket	Adjustable Bracket
Beam Horizontal Angle	90 degrees
Beam Vertical Angle	40 degrees

(1) - Based on a 2 hours test using a continuous 6 dB crest factor pink noise signal band limited according to IEC 268-1 (1985).

(2) - Free field sensitivity (Half Space sensitivity +3 dB)

(3) - Rating based on test signal of filtered random noise conforming to the International Standard IEC 268-1 (pink noise with 12 dB per octave roll-off below 40 Hz and above 5000 Hz with a peak-to average ratio of 6 dB).

S-7601

SUMINISTROS KELONIK SA  
C/ Badajoz, 159 bis - 08018 Barcelona - Spain  
Tel. +34 93 300 43 61  
Updated (DD/MM/YYYY): 14/02/2025



# Enclosure

Dimensions cm (H x W x D) 155 x 63 x 47

Net Weight 59,1 Kg

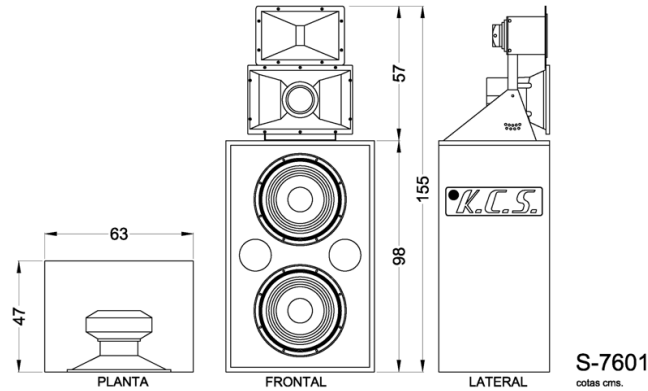

# Components

	Quantity	Reference	Item Code
Enclosure Reference	1	C-215-P/F-7601	47170-A
	-	-	-
LF Reference	2	S-15-P	47202-A
MF Reference	1	S-6	47313-A
HF Reference	1	S-701	47204-A
MF / HF Assembly Kit	1	M/H-7600	47129-A
MF / HF Bracket	1	SP-7600	47347-A
MF Horn	1	BM-941	47324-A
HF Horn	1	BC-94	47239-A

S-7601

## Connectors

Audio Input Connectors

Push Type Terminal

---

## Spare Parts

	Reference	Item Code
LF Recone Kit	GM-S-15-P	47334-A
MF Recone Kit	-	-
HF Recone Kit	GM-S-701	47206-A
Passive Filter	-	-
MF / HF Filter	F-7601	47386-A

---

## EQ Settings

Check the dedicated EQ Setting page on our website  
[https://kcsspeakers.com/en/EQ\\_Setting.html](https://kcsspeakers.com/en/EQ_Setting.html)

---

S-7601